

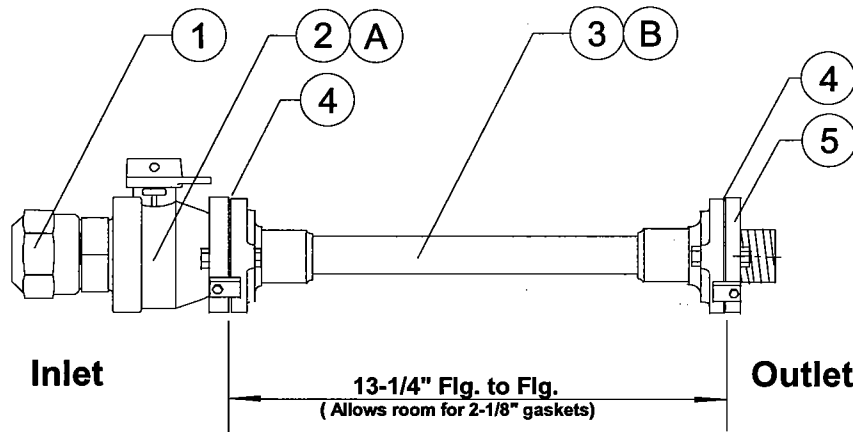

Water T&D Construction Standard

1-1/2" METER SET, DISPLACEMENT W / STRAIGHT VALVE

APPLICATION: Indoor commercial and industrial water metering.



INSTALLATION NOTES

- Customers plumbing shall include a shut off valve on the outlet side of the meter setting or the water meter will not be installed by LBWL.
- Meters shall be installed by LBWL only.
- This complete meter setting, less meter ⑦, idler ③ and meter support ⑥, can be requisitioned as a boxed set using LBWL item # 30-24333.
- **Supports are required for all meter installations. Supports shall be made from non-corrosive materials.**

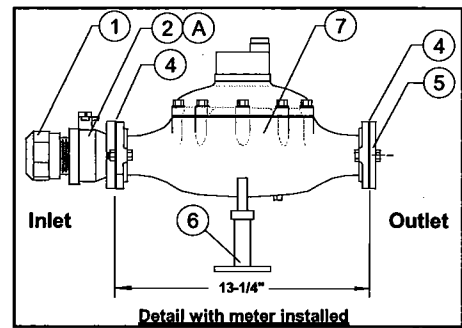

- ① Inlet valve shall be locked in the closed position if no meter is to be installed in the meter setting.
- ② Installation of Meter Idler does not give permission to use unmeasured water. The Meter Idler is used to aid in the assembly of the Meter setting, and will be removed by the LBWL when the meter is installed.

MATERIALS FOR 1-1/2" DISPLACEMENT METER SETTING			
REF	ITEM NO.	QTY*	DESCRIPTION
①	30-26551	1	Coupling, 1-1/2" CTS Comp. x 1-1/2" M.I.P.
②	30-70554	1	Valve, Ball, straight, 1-1/2" meter FLG x 1-1/2" F.I.P.
③	30-19113	1	Adapter, Meter idler, 1-1/2" x 13" (for 1-1/2" meter)
④	30-37108	2	Bolt & gasket set, 1-1/2" flanged meter
⑤	30-29226	1	Flange, 1-1/2" Meter x 1-1/2" F.I.P.
⑥	30-09505	1	Meter support
⑦	30-12453	1	Meter, 1-1/2" SR w/ flanged ends

* Required for one complete setting

Manager, System Integrity & Customer Projects Skwood Date: 3/28/03
 Manager, Water T&D Resource Center B. McLeod Date: 3/28/03